

## LIFT-ACE

Crane Scale  
from 300kg to 2000kg

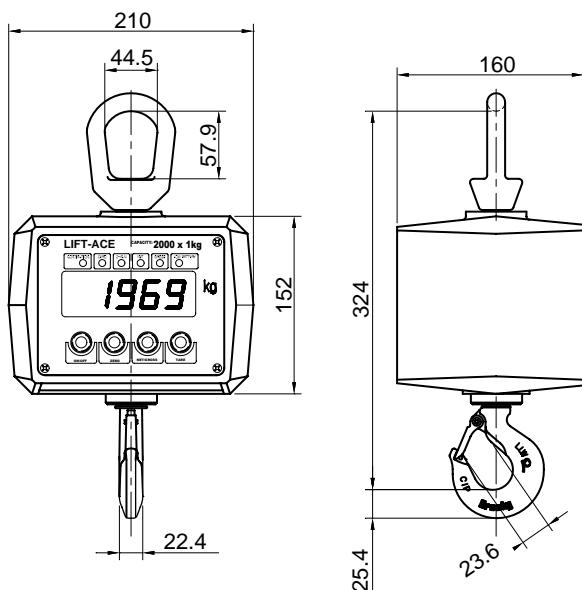

### Features;

- Lightweight portable scale
- Watertight integrity in the harshest environments(IP65 enclosure) cast aluminium housing
- 150 hours running rechargeable battery (LCD type)  
75 hours running rechargeable battery (LED type)
- Sturdy swivel hook ON/OFF, ZERO NET/GROSS, TARE push button switch

### SPECIFICATIONS

Model	ACBD	ACBE
Rated capacity	300, 500, 1000, 2000kg	
Display	LCD (25mm)	LED (25mm)
Accuracy	1/2000, 1/2500, 1/3000	
Power	6 volt lead-acid rechargeable battery	
Battery operating time	150 hours	80 hours
Recharging time	Approx. 4 hours	
Operating temp.	-10 °C ~ 50 °C	
Enclosure	Cast aluminium, IP64	
Safe overload	200% of rated capacity	
Ultimate overload	400% of rated capacity	
Hook	Swivel hook with thrust bearing	
Switches	On/Off, Zero, Net/Gross, Tare	
Annunciators(LED lamp)	Continuation(Auto power OFF), Zero, Net, Gross	
Accessories	Battery charger (Free voltage, AC85~260V)	
Option	1) I.R. Type Remocon 2) Wireless Handy Indicator(Model : BS-52R) 2.4GHz Bluetooth Communication 3) Wireless Desktop Indicator / Large Display	
Weight	Approx. 7 kg	

### ORDERING INFORMATION

<b>ACBE</b>	-	<b>500</b>
MODEL		CAPACITY
ACBE (LED type)		300kg
ACBD (LCD type)		500kg
		1000kg
		2000kg

\* Specifications are subject to change without notice

DEC, 2005