

## HOOK ACE - X

Crane Scale (500kg~5t)



### Features;

- Compact design & High accuracy
- Cast aluminium housing
- 25mm height LCD/LED display
- Sturdy swivel hook("Crosby" or equivalent)
- 24bit Sigma-delta A/D converter
- Easy access rechargeable battery
- Watertight push button switch
- I.R. remote control (on/off, zero, net/gross, tare, hold)
- Optional wireless display & controller

### SPECIFICATIONS

Model	LCBXD	LCBXE
Rated capacity	500kg, 1, 2, 3, 5t	
Display	LCD (25mm)	LED (25mm)
Accuracy	1/2000, 1/2500, 1/3000	
Power	6 volt lead-acid rechargeable battery	
Battery operating time	150 hours	80 hours
Recharging time	Approx. 4 hours	
Operating temp.	-10°C ~ 50°C	
Enclosure	Cast aluminium, IP54	
Safe overload	200% of rated capacity	
Ultimate overload	500% of rated capacity	
Hook	Swivel hook with thrust bearing	
Switches	On/Off, Zero, Net/Gross, Tare	
Annunciators(LED lamp)	Continuation(Auto power OFF), Zero, Net, Gross	
Accessories	(1) Battery, 6 volt rchargeable (2) Battery charger (Free voltage, AC85~260V) (3) I.R. Type Remocon	
Option	1) Wireless Handy Indicator(Model : BS-52R) 2.4GHz Bluetooth Communication 2) Wireless Desktop Indicator / Large Display	

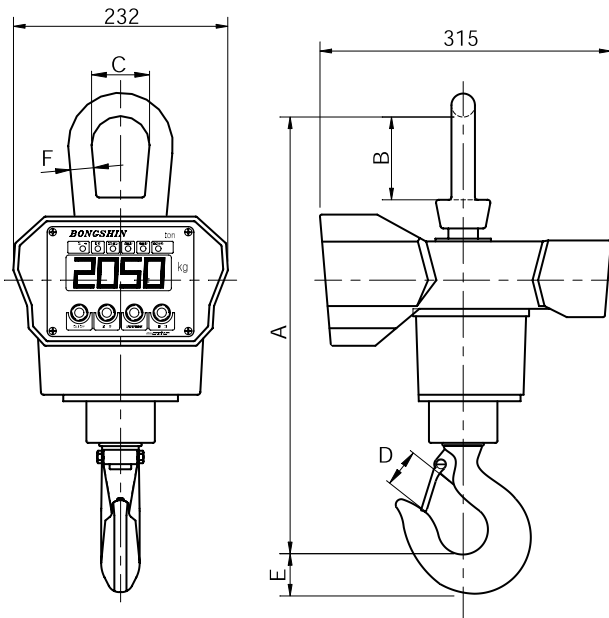

### ORDERING INFORMATION

#### LCBXE - 5T

MODEL: LCBXE, LCBXD  
CAPACITY: 500kg, 1, 2, 3, 5 t



BS-52R (Option)

### Dimmension-mm

MODEL	Capacity	Resolution	A	B	C	D	E	F	Weight
LCBXD(LCBXE)-500kg	500kg	0.2kg	335	67	50	31	29	19	14kg
LCBXD(LCBXE)-1t	1t	0.5kg							
LCBXD(LCBXE)-2t	2t	1kg							
LCBXD(LCBXE)-3t	3t	1kg	470	89	63	43	46	25.4	21kg
LCBXD(LCBXE)-5t	5t	2kg							

\* Specifications are subject to change without notice

DEC, 2005