

## Model DSCS Series

Compression & Tension  
Low Profile Load Cell (200 ~ 1000kg)



The model DSCS is a low profile compression & tension pancake type load cell. All units are machined from a solid billet of stainless steel and sealed with welded diaphragms.

- 17-4PH Stainless steel construction for high accuracy and corrosion resistance
- Hermetically sealed
- High rated output(3mV/V)

### SPECIFICATIONS

MODEL	DSCS
Rated capacity (R.C.)	200, 500, 1000kg
Rated output(R.O.)	3.0mV/V ± 0.3%
Non-linearity	≤0.05% R.O.
Hysteresis	≤0.03% R.O.
Non-repeatability	≤0.03% R.O.
Creep error	≤0.05% in 20min.
Zero balance	≤1% R.O.
Compensated temperature range	-10 ~ 70°C
Operating temperature range	-20 ~ 80°C
Temp. effect on rated output	≤0.03% LOAD/10°C
Temp. effect on zero balance	≤0.03% R.O./10°C
Terminal input resistance	700 Ohms ± 10 Ohms
Terminal output resistance	700 Ohms ± 10 Ohms
Insulation resistance (Min.)	2000 MOhms at 50V DC
Excitation voltage	10V(Recommended), 15V(Max.)
Electrical connection	ø5mmx3m(22AWG x 4Core Shielded)
Protection class	meets IP 67
Safe overload	150% R.C
Ultimate overload	300% R.C

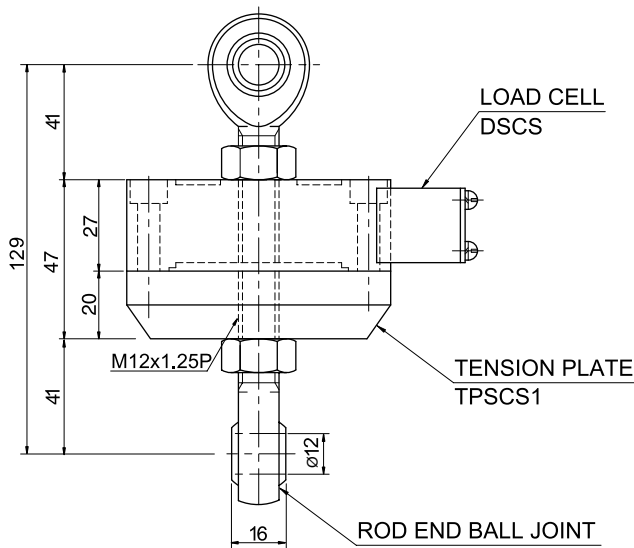
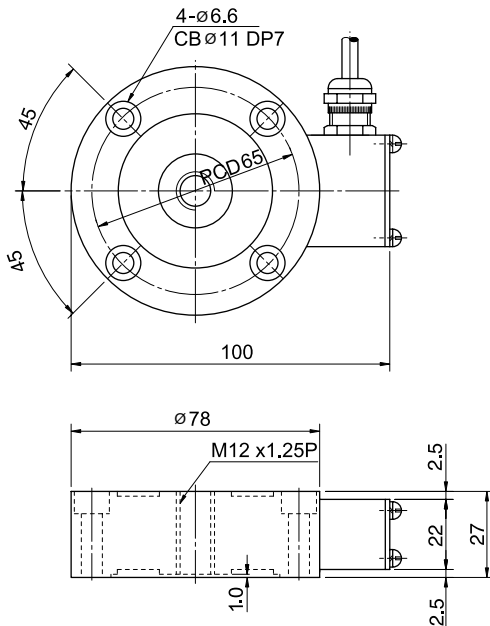

### ORDERING INFORMATION

**DSCS - 200K**  
 MODEL: DSCS      CAPACITY: 200, 500, 1000kg

Weight = 0.9kg

### WIRING INFORMATION

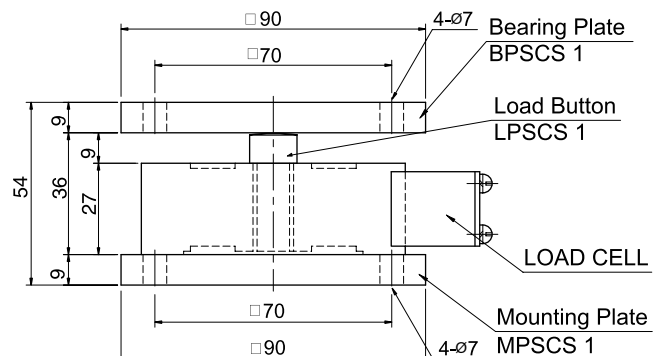
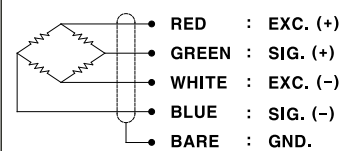

\* Specifications are subject to change without notice

DEC, 2005