

Accu-Max

Crane Scale

from 500kg to 5000kg

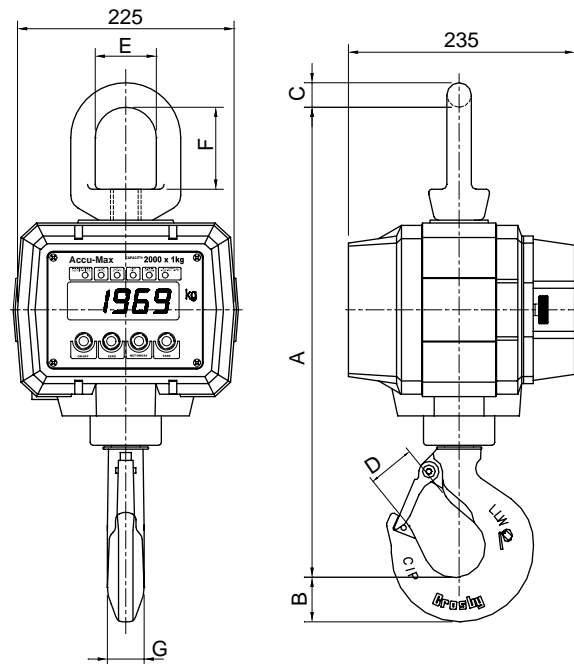

For

- Chemical and steel industries
- Batching operations
- Mining industry
- Shipping operation
- Food processing plants
- Meat packing
- Test facilities
- Foundries
- Automobile manufacturing

Features;

- Heavy duty applications
- Watertight integrity in the harshest environments(IP65 enclosure) cast aluminium housing
- 150 hours running rechargeable battery (LCD type)
60 hours running rechargeable battery (LED type)
- Sturdy swivel hook ON/OFF, ZERO, NET/GROSS, TARE push button switch

SPECIFICATIONS

Model	MCE (LED type)	MCD (LCD type)
Capacity (Division)	500 kg (0.2 kg), 1000 kg (0.5 kg), 2000 kg (1 kg) 3000 kg (1 kg), 5000 kg (2 kg)	
Display	5 digit 7 segment LED(25mm high)	5 digit 7 segment LCD with backlight(25mm high)
Battery life	60 hours between recharging	150 hours between recharging
Accuracy	Plus or minus 0.05% of rated load	
Power	6 volt lead-acid rechargeable battery	
Recharging time	Appr. 8 hours	
Operating temperatures	-10°C ~ 40°C	-10°C ~ 40°C
Enclosure	Cast aluminium, IP65	
Safe overload	200% of rated capacity	
Ultimate overload	400% of rated capacity	
Hook	360 swivel hook	
Pushbutton switches	(1) ON/OFF : ON/OFF and activates 5 minutes automatic shut-off (2) ZERO : Up to 2% of rated capacity (To be zero alarmed with excess of 2% rated capacity) (3) NET/GROSS : Net weight, Gross weight (4) TARE : Up to 100% of rated capacity	
Annunciators	Continuation, Zero, Zero Alarm, Net, Gross, Low battery	
Weight	20.0kg (Approx.)	
Accessories	Battery charger (Free voltage, AC85~260V)	

Model No.	R.C	Resolution	A	B	C	D	E	F	G
500-MCE(MCD)	500 kg	0.2 kg	400.0	29.0	19.0	29.5	50.8	67	23.8
1000-MCE(MCD)	1000 kg	0.5 kg							
2000-MCE(MCD)	2000 kg	1.0 kg	448.3	36.6	25.4	35.8	63.5	85	28.7
3000-MCE(MCD)	3000 kg	1.0 kg	472.0	46.2	25.4	42.9	63.5	85	36.6
5000-MCE(MCD)	5000 kg	2.0 kg							

ORDERING INFORMATION

MCE	-	500	
MODEL		CAPACITY	
MCE (LED type)		500kg 1000kg	
MCD (LCD type)		2000kg 3000kg	
		5000kg	

* Specifications are subject to change without notice

OCT.2002

BONGSHIN LOADCELL CO., LTD.

148,SANGDAEWON-DONG,JUNGWON-KU, SEONGNAM-CITY, GYEONGGI-DO, KOREA
 TEL : 82-31-742-6661 www.bongshin.com
 FAX : 82-31-742-6664 E-mail : loadcell@bongshin.com